

ECLISSE SYNTESIS® LINE

SOLID WALL

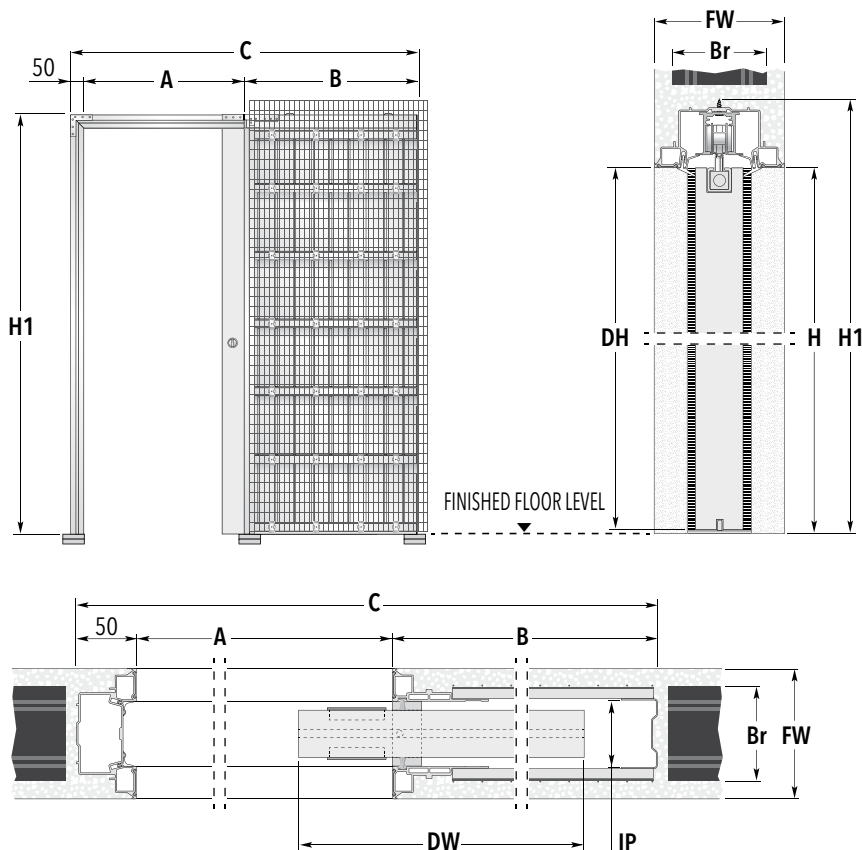

WARNING

Door panels for ECLISSE SYNTESIS® FLUSH sliding pocket door systems must be milled along the upper and lower profiles, as shown below (milling not required on glass doors).

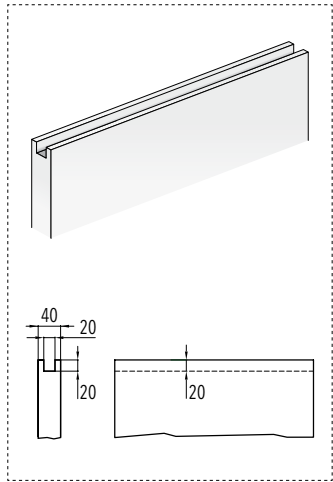

SYSTEMS FOR SINGLE DOOR - Measures related to Italian standards, other dimensions available

PASSAGE SIZE	OVERALL DIMENSIONS		DOOR PANEL*	
A x H	B	C x H1	DW	DH
600 x 2000/2100	750	1393 x 2060/2160	615 ÷ 635	1992/2092
700 x 2000/2100	850	1593 x 2060/2160	715 ÷ 735	1992/2092
800 x 2000/2100	950	1793 x 2060/2160	815 ÷ 835	1992/2092
900 x 2000/2100	1050	1993 x 2060/2160	915 ÷ 935	1992/2092
1000 x 2000/2100	1150	2193 x 2060/2160	1015 ÷ 1035	1992/2092

FINISHED WALL= FW	BRICKS= Br	INTERNAL PASSAGE= IP
108 →	80	54
125 →	100	54
150 →	120	54

Dimensions are given in mm.

NON STANDARD SIZES

- ▶ Passage width
FW 108: 600÷1000 mm
FW 125: 600÷1300 mm
FW 150: 600÷1300 mm
- ▶ Passage height
FW 108: 1000÷2600 mm
FW 125: 1000÷2700 mm
FW 150: 1000÷2700 mm
- ▶ Half sizes need bespoke door panels (e.g. A=650 mm).

NOTES

- ▶ The passage A is reduced by 7 mm.
- ▶ For A>1000 mm, only available wall thickness 125 mm and 150 mm.
- ▶ Max door thickness 40 mm (including any glass holder for glazed door).
- ▶ Max. door weight 100 kg (150 kg on request).
- ▶ Install at finished floor level.
- * Listed measures refer to wooden door panels only.
- ▶ Due to system's productive characteristics and for safety reasons, ECLISSE recommends the door panel protrudes 80 mm.
- ▶ If needed, the adjustable door stop allows to modify the real passage size.
- ▶ In order to ensure that the door disappear completely, a milling is required.
- ▶ The milling for the door guide must have the following dimensions: 7 x 15 mm.

ACCESSORIES

- ▶ ECLISSE SYNTESIS® BASEBOARD
- ▶ ECLISSE BIAS®
- ▶ ECLISSE BIAS®DS
- ▶ Anti-warp profile
- ▶ ECLISSE PUSH&PULL S

